

The Product Name

WPD



Feature

- Manual dresser power by air motor.
- Support arm included.
- Creates surface diameter very closer to original.
- Starter-kit includes Holder: 1 pc, Cutter: 3 pcs.
- Previous Cutter / Holder (KM Cutter) can also be used.
- Simple and strong.
- Available for both $\phi 13$ / $\phi 16$ with same Holder.
- Easy to use by barycentric point located closer to dress-point.

Specification Table

Dimension	L:300mm W: 70mm H: 95
Weight	1.92kg
Recommended Air Pressure	0.5MPa
Rotation Speed	1300rpm
Plug Size	PT-1/4

Dimension

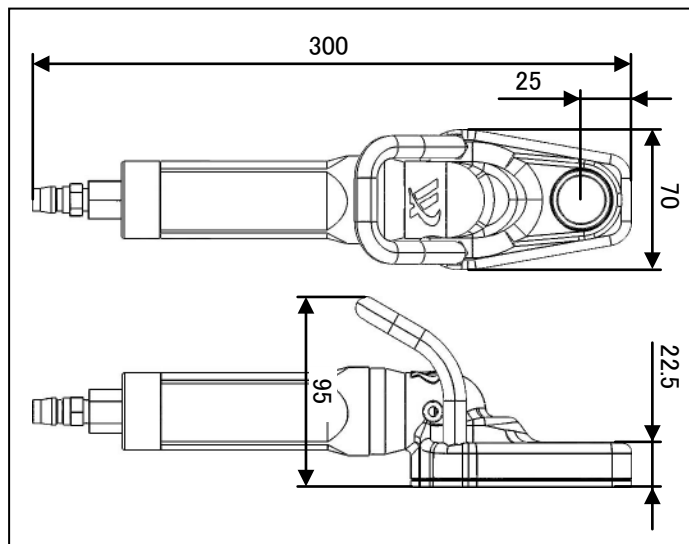

Image of New Cutter/Holder



※Cemented carbide is used for Cutter